

# Ceiling swirl diffusers

## Type VDL

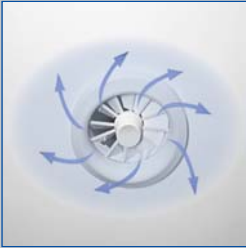

Horizontal swirling air discharge



Adjustable blades



Protective cage



Extended border



### For high rooms, with adjustable air control blades

Circular ceiling swirl diffusers, with manual or motorised adjustment of the air pattern to ensure draught-free ventilation of the occupied zone both in heating and cooling modes

- Nominal sizes 315, 400, 630, 800
- Volume flow rate range 65 – 1080 l/s or 234 – 3888 m<sup>3</sup>/h
- Diffuser face made of galvanised, powder-coated sheet steel and of aluminium
- For supply air
- For variable and constant volume flows
- High induction results in a rapid reduction of temperature differences and airflow velocities
- Discharge direction can be adjusted manually or with an actuator
- Diffuser face with aerodynamically optimised contours
- Ideal for high rooms

#### Optional equipment and accessories

- Exposed diffuser face available in RAL CLASSIC colours
- Horizontal or vertical duct connection
- An extended border improves the horizontal air discharge in cooling mode
- Protective cage for use in gymnasiums
- Actuators for adjusting the air discharge direction
- Diffuser face can be removed from the room side

1

Type		Page
VDL	General information	1.1 – 134
	Order code	1.1 – 140
	Quick sizing	1.1 – 141
	Dimensions and weight	1.1 – 142
	Installation details	1.1 – 150
	Specification text	1.1 – 152
	Basic information and nomenclature	1.6 – 1

Variants

Product examples

VDL-A



VDL-B



VDL-B-V-L



VDL-B-H-L



VDL-B-H-L- K



VDL-B-H-L- S



### Installation examples

#### Freely suspended installation



#### Installation in continuous ceilings



1

#### Description

For detailed information on control units and actuators see Chapter K1 – 10.

#### Application

- Type VDL ceiling swirl diffusers are used as supply air diffusers for high rooms in comfort and industrial zones
- For production halls, gymnasiums, theatres and conference rooms as well as for large internal spaces in airports, railway stations and shopping centres
- For mixed flow ventilation with different air patterns in heating and cooling modes
- Horizontal swirling supply air discharge in cooling mode
- The efficient swirl creates high induction levels, thereby rapidly reducing temperature differences and airflow velocities
- Air discharge from 0° (horizontal) to 90° (vertical)
- For variable and constant volume flows
- For supply air to room air temperature differences from –12 to +15 K
- For room heights exceeding 3.8 m
- With freely suspended installation, an extended border supports the horizontal air discharge in cooling mode

#### Variants

- A: Diffuser face without flange
- B: Diffuser face with flange

#### Connection

- F: Diffuser face only
- H: Horizontal duct connection, with plenum box
- V: Vertical duct connection, with plenum box

#### Diffuser face

- N: Non-removable diffuser face
- D: Removable diffuser face, only in variant with plenum box

#### Nominal sizes

- 315, 400, 630, 800

#### Accessories

- Lip seal
- Electric actuators for adjusting the air discharge direction
- Extended border and protective cage

#### Useful additions

- TDC temperature difference control module

#### Special characteristics

- For high rooms, with adjustable air control blades
- Diffuser face with aerodynamically optimised contours
- The air pattern can be adjusted manually or with an actuator
- Horizontal or vertical duct connection

#### Parts and characteristics

- Circular diffuser face
- Removable or non-removable diffuser face
- Radially arranged fixed or adjustable blades for air discharge from horizontal (0°) to vertical (90°)
- Diffuser face with or without flange
- Adjustment mechanism covered by decorative cap

#### Construction features

- Spigot suitable for circular ducts to EN 1506 or EN 13180
- Spigot with groove for lip seal (if accessory lip seal has been ordered)

### Materials and surfaces

- Blades, casing, duct collar, extended border, plenum box and cross bar made of galvanised sheet steel
- Diffuser face and decorative cap made of aluminium
- Protective cage made of steel mesh
- Blades, duct collar, extended border, plenum box, diffuser face and decorative cap powder-coated RAL 9010, pure white
- P1: Powder-coated, RAL CLASSIC colour

### Installation and commissioning

- Preferably for rooms with a clear height from 3.8 m
- Flush ceiling installation
- VDL-...-K: Also freely suspended installation
- Ceiling distance of at least 300 mm allows for continuous adjustment of the air pattern
- Horizontal or vertical duct connection

### Standards and guidelines

- Sound power level of the air-regenerated noise measured according to EN ISO 5135

### Maintenance

- Maintenance-free as construction and materials are not subject to wear
- Inspection and cleaning to VDI 6022

### VDL-...-X, fixed

Variant	Nominal size				Variant		
	mm				①	②	③
	315	400	630	800	-L-	-K-	-S-
VDL-A-F-X	+	+	+	+	-	-	-
VDL-A-H*-D-X	+	+	+	+	+	-	-
VDL-A-H*-N-X	+	+	+	+	+	-	-
VDL-B-F*-X	+	+	+	+	-	+	+
VDL-B-H*-D*-X	+	+	+	+	+	+	+
VDL-B-H*-N*-X	+	+	+	+	+	+	+

- ① Lip seal
- ② Extended border
- ③ Protective cage
- + Possible
- Not possible

### VDL-...-M, manually adjustable

Variant	Nominal size				Variant		
	mm				①	②	③
	315	400	630	800	-L-	-K-	-S-
VDL-A-F-M	+	+	-	-	-	-	-
VDL-A-V*-D-M	+	+	+	+	+	-	-
VDL-A-V*-N-M	-	-	+	+	+	-	-
VDL-A-H*-D-M	+	+	+	+	+	-	-
VDL-A-H*-N-M	+	+	+	+	+	-	-
VDL-B-F*-M	+	+	-	-	-	+	+
VDL-B-V*-D*-M	+	+	+	+	+	+	+
VDL-B-V*-N*-M	-	-	+	+	+	+	+
VDL-B-H*-D*-M	+	+	+	+	+	+	+
VDL-B-H*-N*-M	+	+	+	+	+	+	+

- ① Lip seal
- ② Extended border
- ③ Protective cage
- + Possible
- Not possible

VDL-...-E\*, with actuator

Variant	Nominal size				Variant		
	mm				①	②	③
	315	400	630	800	-L-	-K-	-S-
VDL-A-V*-D-E*	+	+	+	+	+	-	-
VDL-A-H*-D-E*	+	+	+	+	+	-	-
VDL-B-V*-D*-E*	+	+	+	+	+	+	+
VDL-B-H*-D*-E*	+	+	+	+	+	+	+

- ① Lip seal
- ② Extended border
- ③ Protective cage
- + Possible
- Not possible

Technical data

Nominal sizes	315, 400, 630, 800 mm
Minimum volume flow rate	65 – 320 l/s or 234 – 1152 m <sup>3</sup> /h
Maximum volume flow rate, with $L_{WA} \cong 50$ dB(A)	170 – 1080 l/s or 612 – 3888 m <sup>3</sup> /h
Supply air to room air temperature difference	-12 to +15 K

### Function

#### Functional description

Ceiling swirl diffusers in air conditioning systems create a swirl to supply air to rooms. The resulting airflow induces high levels of room air, thereby rapidly reducing the airflow velocity and the temperature difference between supply air and room air. Ceiling swirl diffusers allow for large volume flow rates. The result is a mixed flow ventilation in comfort zones, with good overall room ventilation, creating only very little turbulence in the occupied zone.

Type VDL ceiling swirl diffusers have adjustable air control blades. Different air patterns allow for cooling or heating mode, or for the adjustment to varying loads. Horizontal air discharge is omnidirectional. Vertical air discharge is possible in heating mode. The supply air to room air temperature difference may range from  $-12$  to  $+15$  K. An actuator (optional) adjusts the blades based on demand.

#### Schematic illustration of the VDL, with plenum box for horizontal duct connection

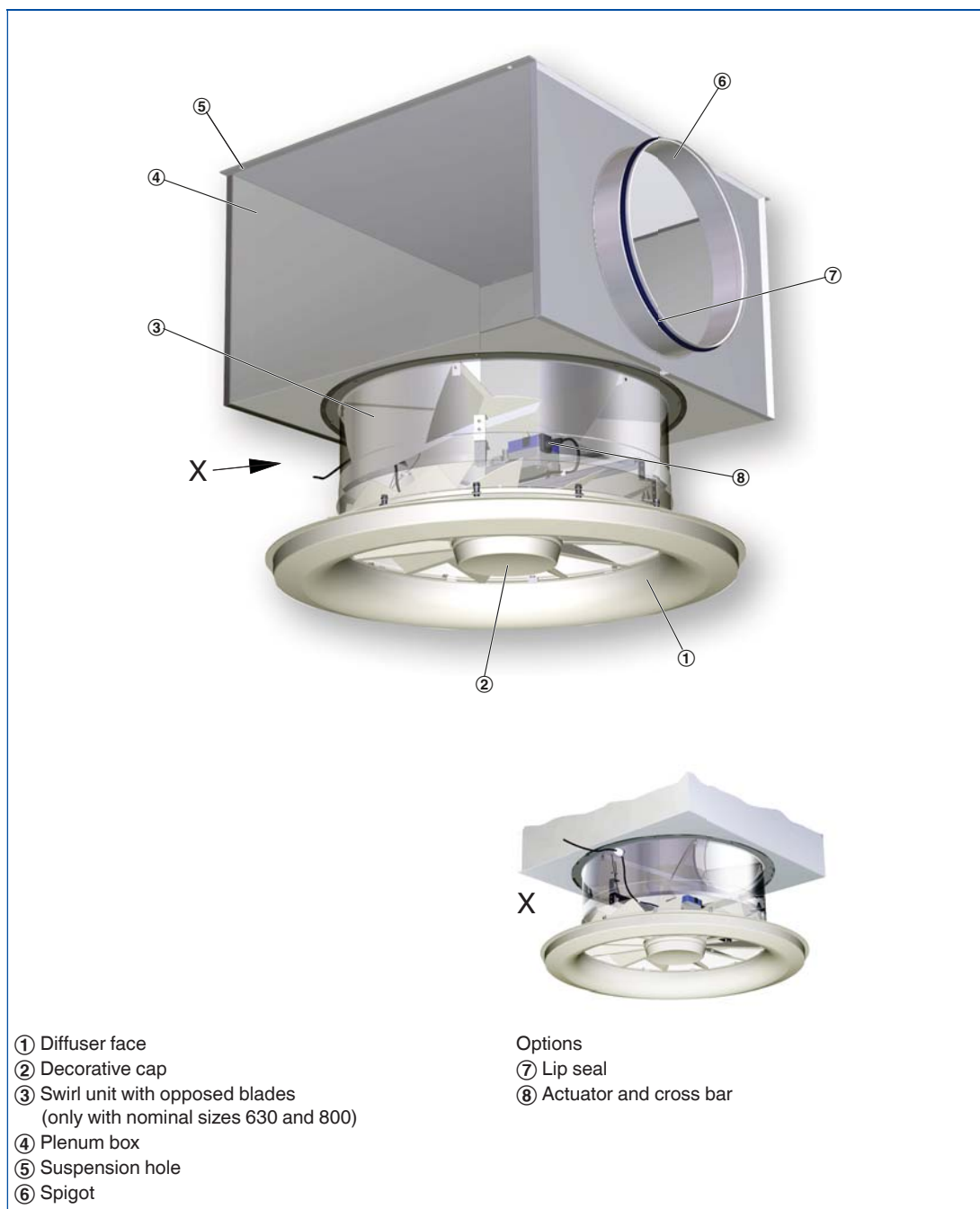

Air patterns

Horizontal air discharge

Horizontal omni directional air discharge

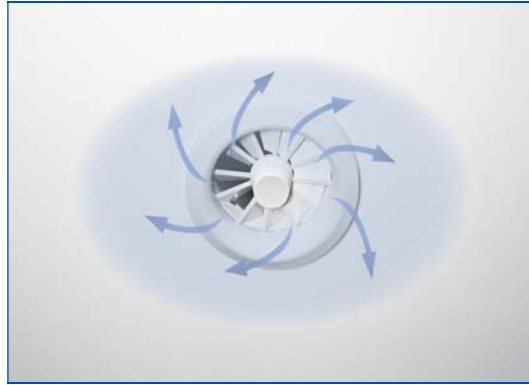

Vertical air discharge

Vertical air discharge



Order code

VDL

VDL - B - H - L - D - S - E3 / 400 / P1 - RAL ...

1 2 3 4 5 6 7 8 9

**1 Type**

VDL Swirl diffuser

**2 Construction style – diffuser face**

A Diffuser face without flange  
B Diffuser face with flange

**3 Connection**

F Diffuser face only  
H Horizontal, with plenum box  
V Vertical, with plenum box

**4 Accessories 1**

No entry: none  
L With lip seal  
(only for connection types V and H)

**5 Diffuser face**

Only in combination with connection H or V  
N Non-removable  
D Removable

**6 Accessories 2**

Only in combination with diffuser face construction style B, supplied separately  
K Extended border  
S Protective cage

**7 Adjustment**

M Manual  
X Without  
(fixed blades, only horizontal air discharge)  
Electric actuator  
E1 230 V AC, 3-point  
E2 24 V AC/DC, 3-point  
E3 24 V AC/DC, modulating 2 – 10 V DC

**8 Nominal size [mm]**

315  
400  
630  
800

**9 Exposed surface of diffuser face**

No entry: powder-coated RAL 9010, pure white  
P1 Powder-coated, specify RAL CLASSIC colour  
Gloss level  
RAL 9010 50 %  
RAL 9006 30 %  
All other RAL colours 70 %

Order example

VDL-B-H-L-S-D-E3/400/P1-RAL 9016

Construction style – diffuser face	With flange
Connection	Horizontal
Accessories 1	Lip seal
Diffuser face	Removable
Accessories 2	Protective cage
Adjustment	Electric actuator 24 V AC, 2 – 10 V DC
Nominal size	400 mm
Exposed surface of diffuser face	RAL 9016, traffic white, gloss level 70 %



### Adjustable

Quick sizing tables provide a good overview of the volume flow rates and corresponding sound power levels and differential pressures.

The maximum volume flow rates apply to a sound power level of approx. 50 dB (A).

Exact values for all parameters can be determined with our Easy Product Finder design programme.

### VDL\*-H-...-M, VDL\*-H-...-E\*

#### Quick sizing – sound power level and total differential pressure

Nominal size	$\dot{V}$		$\Delta p_t$ Pa	$L_{WA}$ dB(A)
	l/s	m <sup>3</sup> /h		
315	65	234	9	22
	100	360	20	34
	135	486	37	43
	170	612	59	50
400	95	342	7	18
	170	612	22	32
	250	900	49	42
	325	1170	82	50
630	235	846	8	23
	365	1314	20	35
	495	1782	38	44
	625	2250	60	50
800	320	1152	8	24
	470	1692	18	35
	620	2232	31	43
	765	2754	47	50

### VDL\*-V-...-M, VDL\*-V-...-E\*, VDL\*-F-M

#### Quick sizing – sound power level and total differential pressure

Nominal size	$\dot{V}$		$\Delta p_t$ Pa	$L_{WA}$ dB(A)
	l/s	m <sup>3</sup> /h		
315	65	234	6	19
	115	414	19	33
	165	594	39	43
	215	774	66	50
400	95	342	5	15
	180	648	19	31
	265	954	41	41
	350	1260	71	50
630	235	846	6	16
	405	1458	18	32
	575	2070	36	43
	730	2628	58	50
800	320	1152	7	20
	500	1800	17	33
	680	2448	32	43
	865	3114	52	50

### Fixed

### VDL\*-H-...-X

#### Quick sizing – sound power level and total differential pressure

Nominal size	$\dot{V}$		$\Delta p_t$ Pa	$L_{WA}$ dB(A)
	l/s	m <sup>3</sup> /h		
315	65	234	7	16
	115	414	23	32
	165	594	48	43
	210	756	78	50
400	95	342	7	14
	180	648	26	32
	265	954	57	44
	325	1170	86	50
630	235	846	8	15
	405	1458	23	33
	575	2070	47	44
	685	2466	67	50
800	320	1152	7	19
	500	1800	17	32
	930	3348	58	50
	920	3312	57	50

### VDL\*-V-...-X, VDL\*-F-X

#### Quick sizing – sound power level and total differential pressure

Nominal size	$\dot{V}$		$\Delta p_t$ Pa	$L_{WA}$ dB(A)
	l/s	m <sup>3</sup> /h		
315	65	234	6	17
	115	414	19	32
	165	594	39	41
	225	810	72	50
400	95	342	5	13
	185	666	20	30
	275	990	45	41
	365	1314	79	50
630	235	846	5	15
	440	1584	17	31
	650	2700	49	47
	840	3024	62	50
800	320	1152	4	22
	570	2052	14	35
	820	2952	28	43
	1080	3888	49	50

1

- A -  
- B -

Order code detail

**VDL-A**



**Diffuser face VDL-A**

- Diffuser face without flange

**Nominal sizes**

- 315, 400, 630, 800

**VDL-B**



**Diffuser face VDL-B**

- Diffuser face with flange

**Nominal sizes**

- 315, 400, 630, 800

### Dimensions

**VDL-A**

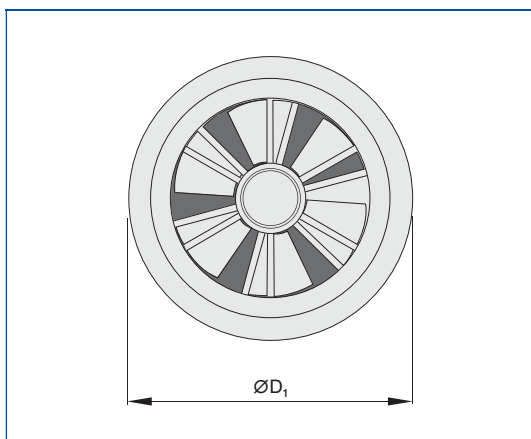

**VDL-B**

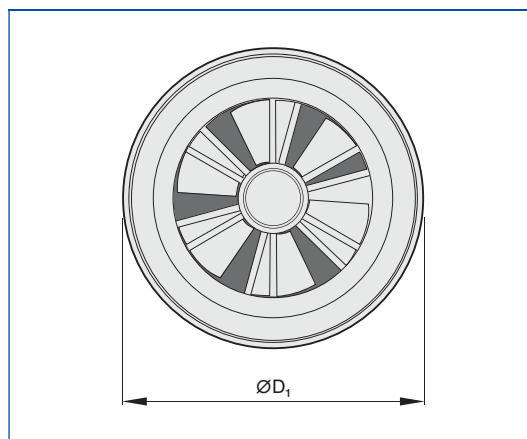

**VDL-A**

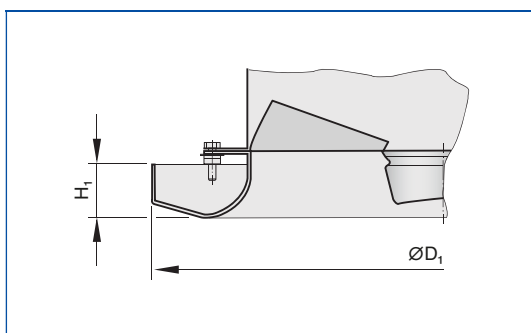

**VDL-B**

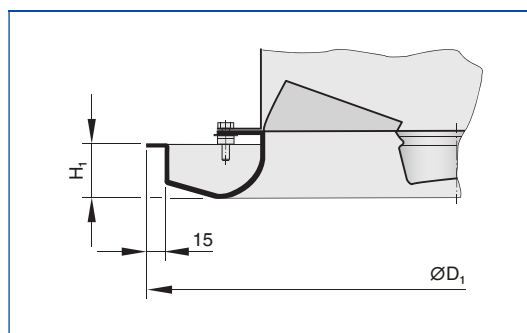

### Dimensions

Nominal size	VDL-A	VDL-B	H <sub>1</sub>	A <sub>eff</sub> m <sup>2</sup>
	ØD <sub>1</sub>			
	mm			
315	464	494	42	0.022
400	567	597	45	0.031
630	871	901	51	0.077
800	1077	1107	55	0.106

- * - X
- * - M

Order code detail

### Variant VDL\*-F-X

- Diffuser face with fixed air control blades

### Nominal sizes

- 315, 400, 630, 800

### Parts and characteristics

- Circular duct collar for connection to a vertical duct

### Construction features

- Spigot suitable for circular ducts to EN 1506 or EN 13180

### Variant VDL\*-F-M

- Diffuser face with alternately fixed and adjustable blades, for air discharge from horizontal (0°) to vertical (90°)

### Nominal sizes

- 315, 400, 630, 800

### Parts and characteristics

- Circular duct collar for connection to a vertical duct

### Construction features

- Spigot suitable for circular ducts to EN 1506 or EN 13180

## Dimensions

### VDL\*-F-X

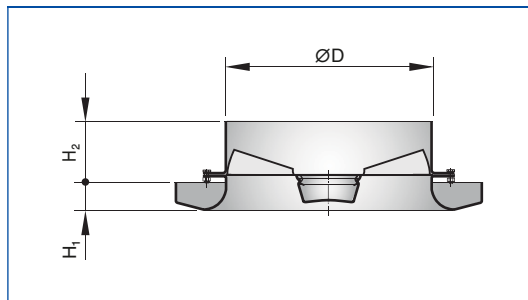

Illustration shows VDL-A-F-X

### VDL\*-F-M

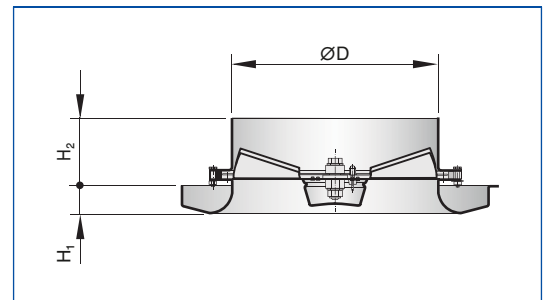

Illustration shows VDL-A-F-M

### Dimensions [mm] and weight [kg]

Nominal size	H <sub>1</sub>	H <sub>2</sub>	ØD	m
	mm			kg
315	42	103	313	3
400	45	112	398	4
630	51	153	628	11
800	55	174	798	19

VDL\*-F-M only nominal sizes 315, 400

1

- \* - H - N  
- \* - H - D

Order code detail

### Variant VDL\*-H-N

- With plenum box for horizontal duct connection
- Non-removable diffuser face

### Nominal sizes

- 315, 400, 630, 800

### Parts and characteristics

- Plenum box for horizontal duct connection
- Lip seal (optional)

### Construction features

- Spigot suitable for circular ducts to EN 1506 or EN 13180
- Spigot with groove for lip seal (if accessory lip seal has been ordered)

### Variant VDL\*-H-D

- With plenum box for horizontal duct connection
- Removable diffuser face
- Actuator for blade adjustment, optional

### Nominal sizes

- 315, 400, 630, 800

### Parts and characteristics

- Plenum box for horizontal duct connection
- Lip seal (optional)

### Construction features

- Spigot suitable for circular ducts to EN 1506 or EN 13180
- Spigot with groove for lip seal (if accessory lip seal has been ordered)

### VDL\*-H-N

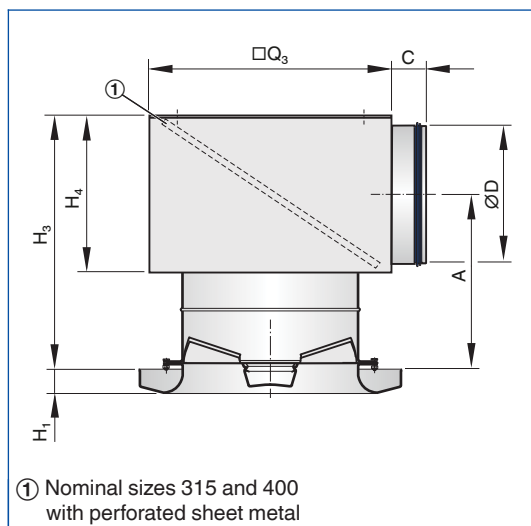

Illustration shows VDL-A-H-L-N-M

### VDL\*-H-D

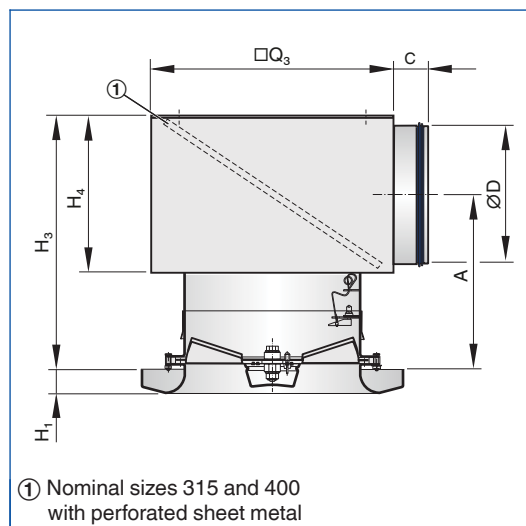

Illustration shows VDL-A-H-L-D-M

### Dimensions [mm] and weight [kg]

Nominal size	H <sub>1</sub>	□Q <sub>3</sub>	H <sub>3</sub>	H <sub>4</sub>	ØD	A	C	m
	mm							kg
315	42	435	432	282	248	290	65	11
400	45	500	536	368	313	351	65	16
630	51	750	761	468	398	526	65	35
800	55	1000	1026	568	498	741	65	59

Weights apply to the variant with actuator

Removable diffuser face

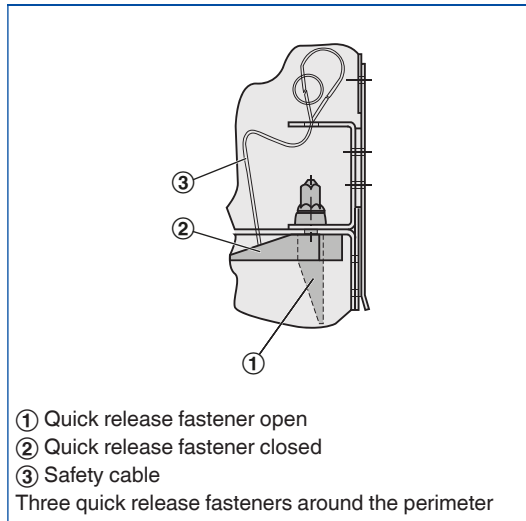

1

- \* - V - N  
- \* - V - D

Order code detail

### Variant VDL-\*-V-N

- With plenum box for vertical duct connection
- Non-removable diffuser face

### Nominal sizes

- 630, 800

### Parts and characteristics

- Plenum box for vertical duct connection
- Lip seal (optional)

### Construction features

- Spigot suitable for circular ducts to EN 1506 or EN 13180
- Spigot with groove for lip seal (if accessory lip seal has been ordered)

### Variant VDL-\*-V-D

- With plenum box for vertical duct connection
- Removable diffuser face
- Actuator for blade adjustment, optional

### Nominal sizes

- 315, 400, 630, 800

### Parts and characteristics

- Plenum box for vertical duct connection
- Lip seal (optional)

### Construction features

- Spigot suitable for circular ducts to EN 1506 or EN 13180
- Spigot with groove for lip seal (if accessory lip seal has been ordered)

## Dimensions

### VDL-\*-V-N

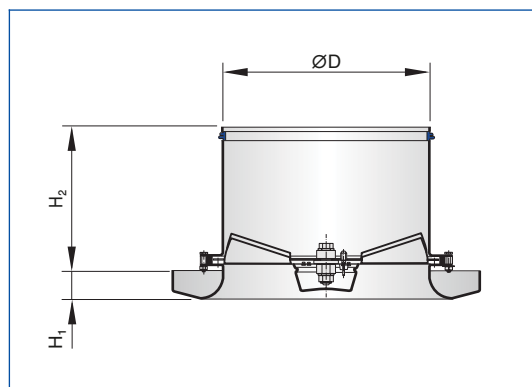

Illustration shows VDL-A-V-L-N-M

### VDL-\*-V-D

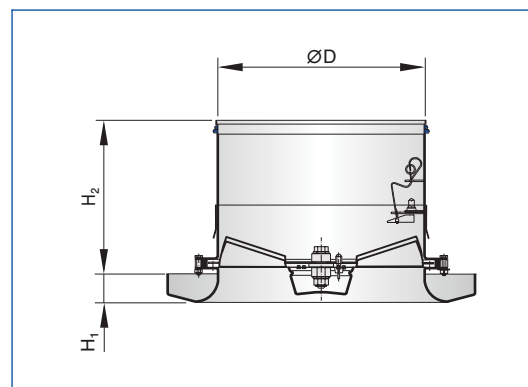

Illustration shows VDL-A-V-L-D-M

### Dimensions [mm] and weight [kg]

Nominal size	VDL-*-V-N	VDL-*-V-D	H <sub>1</sub>	ØD	m
	H <sub>2</sub>				
	mm				kg
315		219	42	313	6
400		228	45	398	8
630	316	316	51	628	19
800	483	483	55	798	33

Weights apply to the variant with actuator

Removable diffuser face

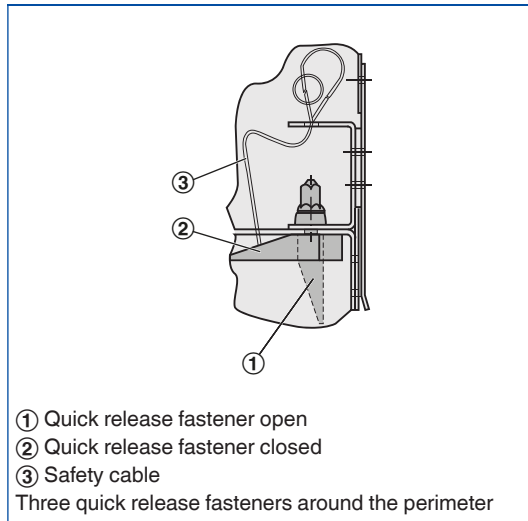

# 1

- K /

Order code detail

### Accessories

- Extended border
- Only for diffuser faces with flange (VDL-B)

### Nominal sizes

- 315, 400, 630, 800

### Parts and characteristics

- An extended border supports the horizontal air discharge in cooling mode

### Dimensions

### Extended border

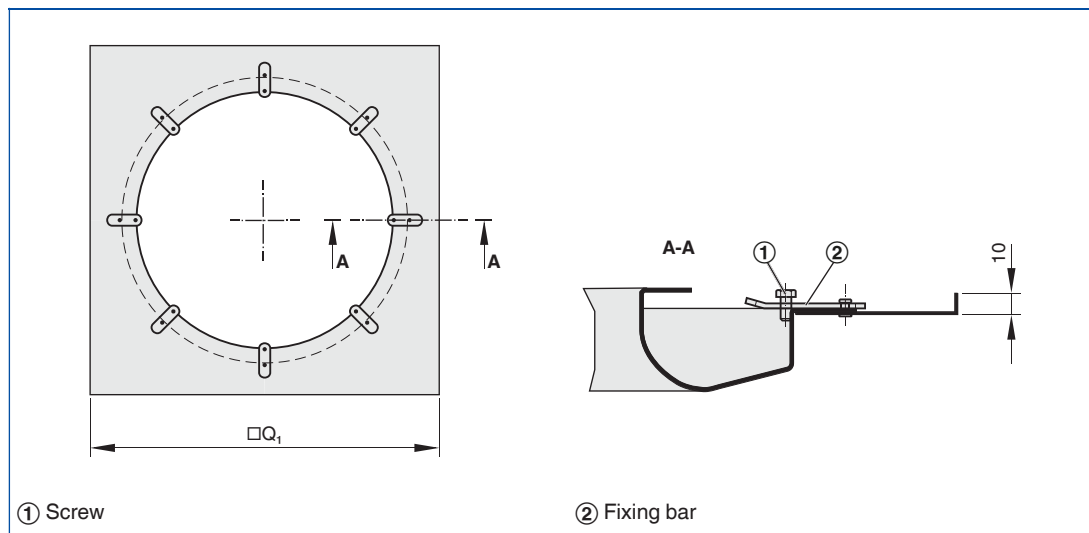

### Dimensions [mm] and weight [kg]

Nominal size	$\square Q_1$	m
	mm	kg
315	630	2
400	800	3
630	1260	8
800	1600	13



- S /

Order code detail

**Accessories**

- Protective cage
- Only for diffuser faces with flange (VDL-B)

**Nominal sizes**

- 315, 400, 630, 800

**Parts and characteristics**

- A protective cage protects the blades, e.g. in gymnasiums

**Dimensions**

**Protective cage**

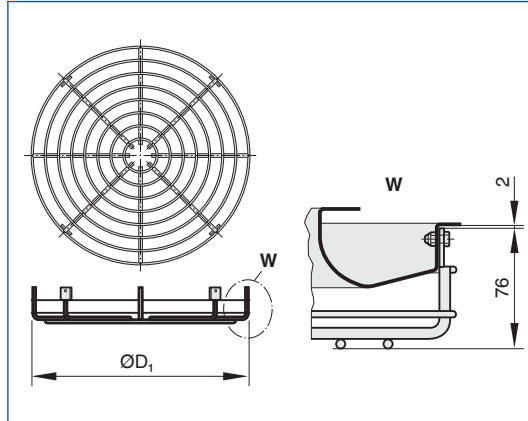

**Dimensions [mm] and weight [kg]**

Nominal size	ØD <sub>1</sub>	m
	mm	kg
315	488	3
400	591	3
630	895	6
800	1101	9

## Description

### Installation information

- Installation can be flush with the ceiling or freely suspended
- If the VDL is mounted flush with an open cell ceiling, the resulting air pattern is the same as with freely suspended installation
- Continuous adjustment of the air pattern using an actuator is only possible with freely suspended installation, installation flush with an open cell ceiling, or installation with the diffuser protruding from an open cell ceiling
- Installation and making connections to be performed by others

## Installation types

These are only schematic diagrams to illustrate installation details.

### Flush ceiling installation

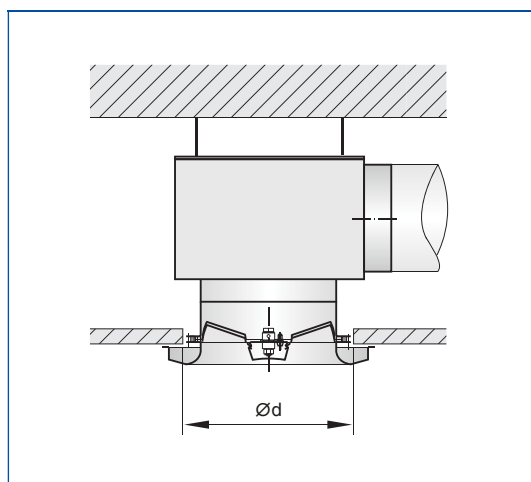

- Two discharge directions, horizontal and vertical
- Horizontal or vertical duct connection

### Protruding installation

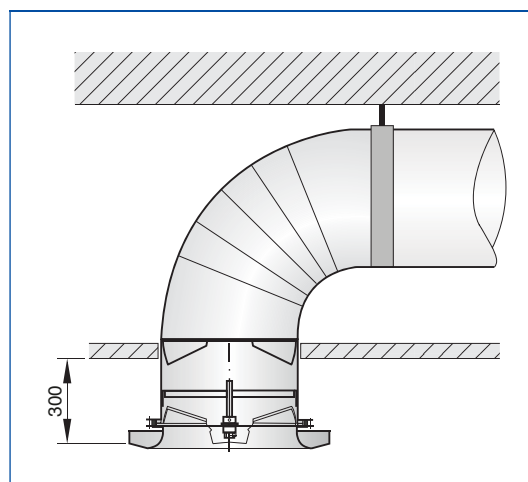

- Continuous adjustment of the discharge direction
- Vertical duct connection
- 300 mm minimum distance to the suspended ceiling

## Ceiling cut-out

### Dimensions

Nominal size	Ød	
	mm	
315		400
400		500
630		750
800		950

Freely suspended installation

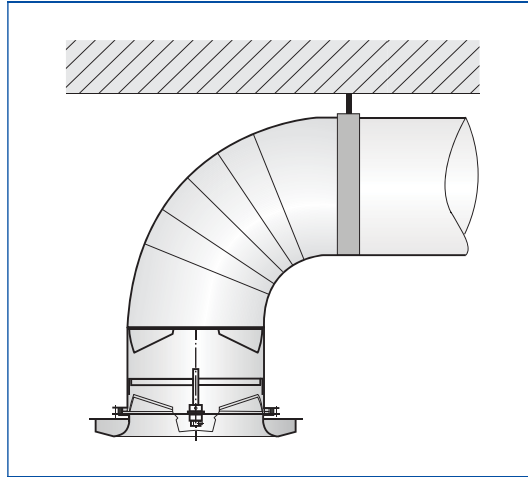

- Continuous adjustment of the discharge direction
- Horizontal or vertical duct connection
- Preferably for industrial zones

Freely suspended installation of VDL-...-K

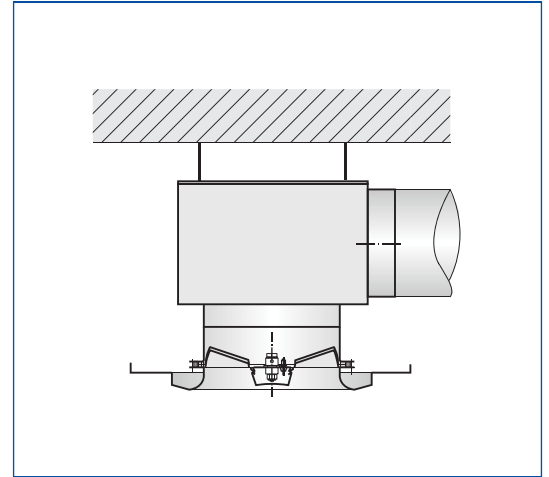

- Two discharge directions, horizontal and vertical
- An extended border supports the horizontal air discharge
- Horizontal or vertical duct connection
- Preferably for comfort zones

### Standard text

This specification text describes the general properties of the product. Texts for variants can be generated with our Easy Product Finder design programme.

Ceiling swirl diffuser with circular diffuser face for high rooms in comfort and industrial zones. For supply air only. With fixed air control blades for horizontal supply air discharge and with adjustable blades for air discharge from horizontal (0°) to vertical (90°). Horizontal air discharge with high induction. For freely suspended installation and for suspended ceilings.

Ready-to-install component which consists of the diffuser face, blades, duct collar or plenum box with side entry or top entry spigot, and suspension holes. Removable or non-removable diffuser face. The removable diffuser face is fixed to the cross bar with a central screw, covered by a decorative cap.

Spigot suitable for ducts to EN 1506 or EN 13180. Sound power level of the air-regenerated noise measured according to EN ISO 5135.

### Special characteristics

- For high rooms, with adjustable air control blades
- Diffuser face with aerodynamically optimised contours
- The air pattern can be adjusted manually or with an actuator
- Horizontal or vertical duct connection

### Materials and surfaces

- Blades, casing, duct collar, extended border, plenum box and cross bar made of galvanised sheet steel
- Diffuser face and decorative cap made of aluminium
- Protective cage made of steel mesh
- Blades, duct collar, extended border, plenum box, diffuser face and decorative cap powder-coated RAL 9010, pure white
- P1: Powder-coated, RAL CLASSIC colour

### Technical data

- Nominal sizes: 315, 400, 630, 800 mm
- Minimum volume flow rate: 65 – 320 l/s or 234 – 1152 m<sup>3</sup>/h
- Maximum volume flow rate, with  $L_{WA} \approx 50$  dB(A): 170 – 1080 l/s or 612 – 3888 m<sup>3</sup>/h
- Supply air to room air temperature difference: -12 to +15 K

### Sizing data

- $\dot{V}$  \_\_\_\_\_ [m<sup>3</sup>/h]
- $\Delta p_t$  \_\_\_\_\_ [Pa]
- $L_{WA}$  Air-regenerated noise \_\_\_\_\_ [dB(A)]

### Order options

#### 1 Type

**VDL** Swirl diffuser

#### 2 Construction style – diffuser face

- A** Diffuser face without flange
- B** Diffuser face with flange

#### 3 Connection

- F** Diffuser face only
- H** Horizontal, with plenum box
- V** Vertical, with plenum box

#### 4 Accessories 1

- No entry: none
- L** With lip seal (only for connection types V and H)

#### 5 Diffuser face

- Only in combination with connection H or V
- N** Non-removable
- D** Removable

#### 6 Accessories 2

- Only in combination with diffuser face construction style B, supplied separately
- K** Extended border
- S** Protective cage

#### 7 Adjustment

- M** Manual
- X** Without (fixed blades, only horizontal air discharge) Electric actuator
- E1** 230 V AC, 3-point
- E2** 24 V AC/DC, 3-point
- E3** 24 V AC/DC, modulating 2 – 10 V DC

#### 8 Nominal size [mm]

- 315**
- 400**
- 630**
- 800**

#### 9 Exposed surface of diffuser face

- No entry: powder-coated RAL 9010, pure white
- P1** Powder-coated, specify RAL CLASSIC colour
- Gloss level
- RAL 9010 50 %
- RAL 9006 30 %
- All other RAL colours 70 %

# Ceiling diffusers

## Basic information and nomenclature



- Product selection
- Principal dimensions
- Nomenclature
- Sizing and sizing example
- Installation information
- Commissioning

# Ceiling diffusers

## Basic information and nomenclature

### Product selection

	Ceiling swirl diffusers								
	AIRNAMIC	VDW	TDV-SilentAIR	RFD	FD	TDF-SilentAIR	VD	VDL	FDE
<b>Diffuser face style</b>									
Circular	●	●	●	●	●	●		●	
Square	●						●		●
<b>Diffuser face</b>									
Circular	●	●	●	●	●	●		●	
Square	●	●	●	●	●	●	●		●
Galvanised sheet steel		●	●	●	●	●		●	●
Aluminium				●			●		
Plastic	●								
<b>Air control blades</b>									
Fixed	●			●	●	●			●
Adjustable		●	●				●	●	
Plastic, black and white		●	●						
<b>Duct connection</b>									
Horizontal	●	●	●	●	●	●	●	●	●
Vertical		●	●	●	●	●	●	●	
FLEXTRO	●	●	●		●	●			
<b>Attachments</b>									
Damper blade	●	●	●	●	●	●			●
Pressure tap		●	●	●	●	●			●
Actuator							●	●	
<b>Accessories</b>									
Lip seal	●	●	●	●	●	●			●
Protective cage							●	●	
Extended border							●	●	
<b>Nominal sizes</b>									
Circular diffuser face	400, 600	300, 400, 500, 600, 625	300, 400, 500, 600, 625		300, 400, 500, 600, 625	300, 400, 500, 600, 625			
Square diffuser face	300, 600, 625	300, 400, 500, 600, 625, 825					425, 600, 775, 1050		600, 625
Spigot*				125, 160, 200, 250, 315, 400				315, 400, 630, 800	250, 315
<b>Technical data</b>									
Volume flow rate range [l/s]	13 – 385	7 – 470	11 – 315	4 – 330	9 – 235	10 – 295	95 – 1490	65 – 1080	51 – 365
Volume flow rate range [m³/h]	47 – 1386	25 – 1692	40 – 1134	14 – 1188	31 – 846	36 – 1026	342 – 5364	234 – 3888	184 – 1314
Supply air to room air temperature difference	-12 – +10 K						-12 – +15 K		-12 – +10 K
●	Possible								
	Not possible								

\*Nominal diameter

# Ceiling diffusers

## Basic information and nomenclature

### Product selection

1

	Design ceiling swirl diffusers		Ceiling swirl diffusers with perforated face plate
	XARTO	ADD	DCS
<b>Diffuser face style</b>			
Circular	●	●	●
Square	●		●
<b>Diffuser face</b>			
Circular	●	●	
Square	●	●	●
Galvanised sheet steel	●	●	●
Aluminium			
Plastic			
<b>Air control blades</b>			
Fixed	●	●	●
Adjustable			
Plastic, black and white			
<b>Duct connection</b>			
Horizontal	●	●	●
Vertical		●	●
FLEXTRO			
<b>Attachments</b>			
Damper blade	●	●	
Pressure tap		●	
Actuator			
<b>Accessories</b>			
Lip seal	●	●	
Protective cage			
Extended border			
<b>Nominal sizes</b>			
Circular diffuser face	600	250, 300, 450, 500, 600	
Square diffuser face	600, 625	250, 300, 450, 500, 600, 625	600, 625
Spigot*		125, 160, 200, 250, 315	125, 160, 200, 250, 315, 400
<b>Technical data</b>			
Volume flow rate range [l/s]	31 – 265	20 – 465	4 – 260
Volume flow rate range [m <sup>3</sup> /h]	110 – 954	72 – 1674	16 – 936
Supply air to room air temperature difference	-12 – +10 K		
●	Possible		
	Not possible		

\*Nominal diameter

# Ceiling diffusers

## Basic information and nomenclature

### Product selection

1

	Ceiling diffusers						
	VDR	ADLQ	DLQ	ADLR	DLQL	DLQ-AK	DLK-Fb
<b>Diffuser face style</b>							
Circular	●			●			
Square		●	●		●	●	●
<b>Diffuser face</b>							
Circular	●			●			
Square		●	●	●	●	●	●
Galvanised sheet steel			●		●	●	●
Aluminium	●	●		●			
Plastic							
<b>Air control blades</b>							
Fixed		●	●	●	●	●	●
Adjustable	●						
Plastic, black and white							
<b>Duct connection</b>							
Horizontal	●	●	●	●	●	●	●
Vertical	●			●	●		
FLEXTRO		●					
<b>Attachments</b>							
Damper blade		●	●	●	●		
Pressure tap		●	●	●			
Actuator	●						
<b>Accessories</b>							
Lip seal		●	●	●	●		
Protective cage							
Extended border							
<b>Nominal sizes</b>							
Circular diffuser face	630, 800			244, 300, 356, 412, 468, 542, 598, 654			
Square diffuser face		250, 300, 400, 500, 600, 625	250, 300, 400, 500, 600, 625	600 625	250, 300, 400, 500, 600	300, 400, 500, 600, 625	600, 625
Spigot*	315, 400, 630, 800						
<b>Technical data</b>							
Volume flow rate range [l/s]	175 – 1495	20 – 665	20 – 700	20 – 650	6 – 285	40 – 565	220 – 460
Volume flow rate range [m³/h]	630 – 5382	72 – 2394	72 – 2520	72 – 2340	22 – 1026	144 – 2034	792 – 1656
Supply air to room air temperature difference	-10 to +15 K	-10 to +10 K					
●	Possible						
○	Not possible						

\*Nominal diameter



# Ceiling diffusers

## Basic information and nomenclature

### Principal dimensions

**ØD [mm]**

Outside diameter of the spigot

**ØD<sub>1</sub> [mm]**

Outer diameter of a circular diffuser face

**ØD<sub>2</sub> [mm]**

Diameter of a circular diffuser face style

**ØD<sub>3</sub> [mm]**

Diameter of a circular plenum box

**□Q<sub>1</sub> [mm]**

Outer diameter of a square diffuser face

**□Q<sub>2</sub> [mm]**

Dimensions of a square diffuser face style

**□Q<sub>3</sub> [mm]**

Dimensions of a square plenum box

**H<sub>1</sub> [mm]**

Distance (height) from the lower edge of the suspended ceiling to the lower edge of the diffuser face

**H<sub>2</sub> [mm]**

Height of a ceiling diffuser, from the lower edge of the suspended ceiling to the upper edge of the spigot

**H<sub>3</sub> [mm]**

Height of a ceiling diffuser with plenum box, from the lower edge of the suspended ceiling to the upper edge of the plenum box or of the spigot

**A [mm]**

Position of the spigot, defined by the distance of the spigot centre line to the lower edge of the suspended ceiling

**C [mm]**

Length of the spigot

**m [kg]**

Weight

### Nomenclature

**L<sub>WA</sub> [dB(A)]**

A-weighted sound power level of air-regenerated noise

 **$\dot{V}$  [m<sup>3</sup>/h] and [l/s]**

Volume flow rate

**Δt<sub>z</sub> [K]**

Supply air temperature difference

**Δp<sub>t</sub> [Pa]**

Total differential pressure

**A<sub>eff</sub> [m<sup>2</sup>]**

Effective air discharge area

All sound power levels are based on 1 pW.

# Ceiling diffusers

## Basic information and nomenclature

### 1 Sizing with the help of this catalogue

This catalogue provides convenient quick sizing tables for ceiling diffusers. The tables give supply air volume flow rates for all nominal sizes. The maximum volume flow rates are for an open damper blade. A smaller opening of the damper blade results in higher sound power levels and a higher total differential pressure. The tables show values for damper blade positions 45° and 90°.

Sizing data for other volume flow rates and damper blade positions can be determined quickly and precisely using the Easy Product Finder design programme.

### Sizing example

#### Given data

$\dot{V} = 300 \text{ l/s}$  (1280 m<sup>3</sup>/h)  
 Square ceiling diffuser, steel,  
 with fixed air control blades  
 Maximum sound power level 40 dB(A)  
 with damper blade position 45°  
 Four-way air discharge

#### Quick sizing

Type DLQ  
 Nominal sizes: 600, 625  
 Selected: DLQ/600

### Easy Product Finder



The Easy Product Finder allows you to size products using your project-specific data.

You will find the Easy Product Finder on our website.

The screenshot shows the 'Easy Product Finder' software interface. The main window displays the following information:

- Project Structure:** Projekt 1
- Product Selection:** DLQ AK // 600 // 0 // 0 // 0 // RAL 9010
- Input Parameters:**
  - Volumenstrom [m<sup>3</sup>/s]:  $\dot{V} = 1.280$  (792 - 2795)
  - Zwischenräume/Abstände [m]:
    - $a = 6.00$  (x2,0)
    - $b_1 = 1.20$  (1,0, 2,0)
    - $x = 3.00$  (x1,2)
    - $l = b_1, s, x = 4,2$
  - Temperaturunterschied [K]:  $\Delta T_2 = -8,0$  (-12,0 - 4,4)
- Technical Results:**
  - $v_{10} = 0,15$  m/s
  - $\Delta p_{10} = -1,3$  K
  - $v_1 = 0,32$  m/s
  - $\Delta p_1 = -1,3$  K
- Acoustic Results (0° = Kompletzt geöffnet):**

Zu/R	dB(A)	Pa
dot	34	
LWA	28	
LWNC	22	

# Ceiling diffusers

## Basic information and nomenclature

### Description

### Installation information

- Installation and making connections to be performed by others
- The optimum aerodynamic function is only achieved with flush ceiling installation
- The diffuser face is fixed to the plenum box cross bar using the central fixing screw
- Central fixing screw is concealed by a decorative cap

### Installation types

#### Flush ceiling installation with square plenum box

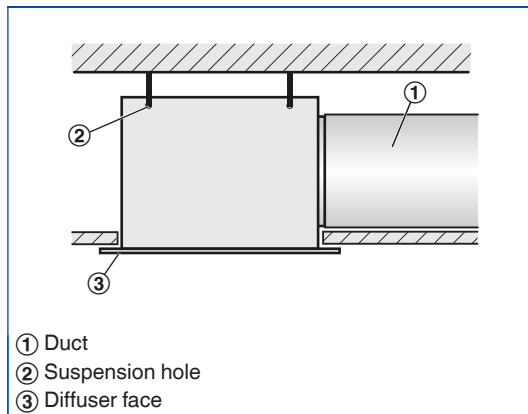

- Horizontal duct connection
- Four suspension holes
- Suspension with cords, wires or hangers, to be provided by others

#### Flush ceiling installation with circular plenum box

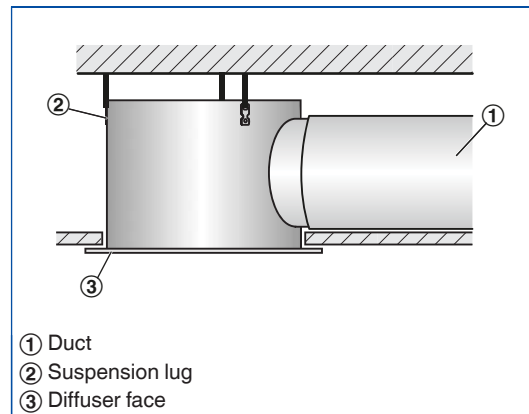

- Horizontal duct connection
- Three suspension lugs
- Suspension with cords, wires or hangers, to be provided by others

#### Flush ceiling installation with plenum box FLEXTRO

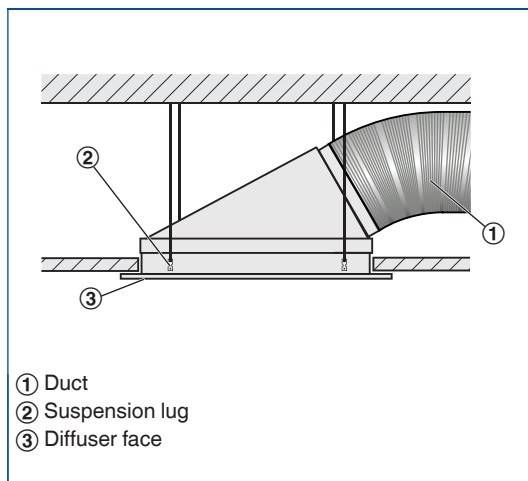

- Spigot at 30° angle
- Four suspension lugs
- Suspension with cords, wires or hangers, to be provided by others

#### Freely suspended installation

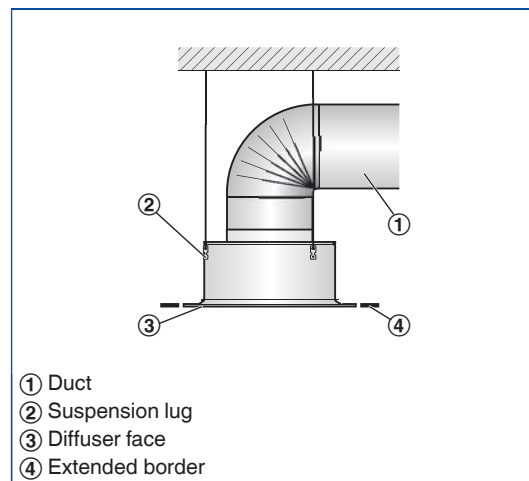

- Vertical duct connection
- Three suspension lugs
- Suspension with cords, wires or hangers, to be provided by others

# Ceiling diffusers

## Basic information and nomenclature

### 1 Installation without plenum box

#### Flush ceiling installation with standard cross bar G1, screw-fixed to ceiling

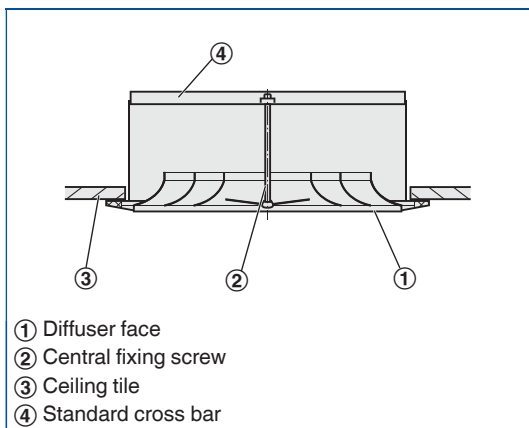

- No spigot
- Fixing of the standard cross bar to the ceiling tile is to be performed by others

#### Flush ceiling installation with standard cross bar G1, with fixing tabs mortared in

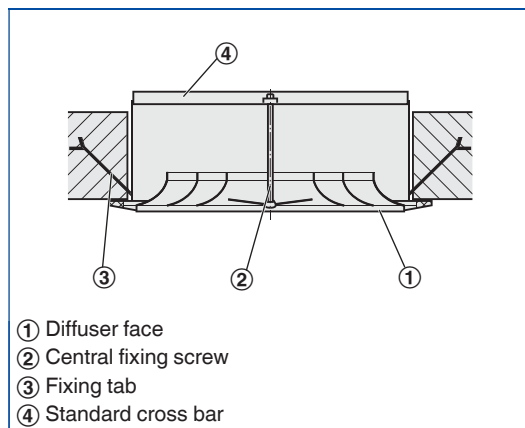

- No spigot
- The standard cross bar has to be mortared into the ceiling by others

#### Flush ceiling installation with duct cross bar E1

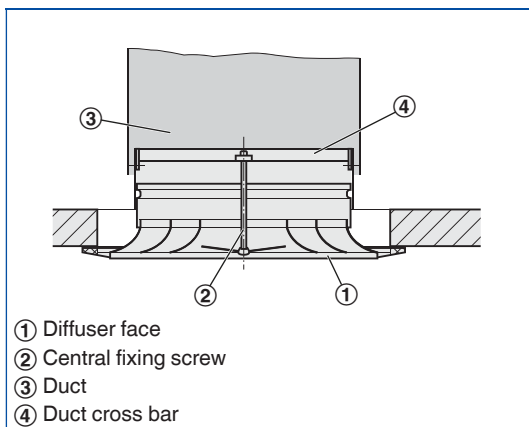

- Vertical duct connection
- Fixing of the duct cross bar to the duct is to be performed by others

### Ceiling systems

#### Installation into grid ceilings

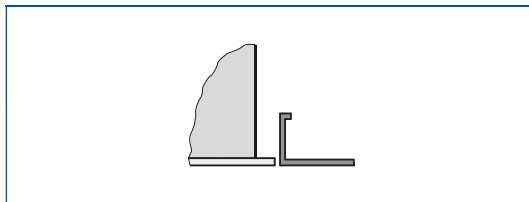

- Fix the plenum box to the ceiling
- The ceiling tile of the grid ceiling is independent of the ceiling diffuser
- Fix the diffuser face after the ceiling has been completed

#### Installation in continuous ceilings

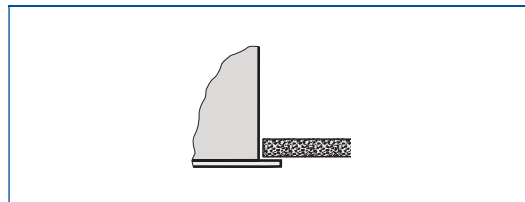

- Fix plenum box (including diffuser face, if necessary) to the ceiling
- Adjust plasterboard ceiling tile as required
- If necessary, fix the diffuser face after the ceiling has been completed

### Installation in T-bar ceilings

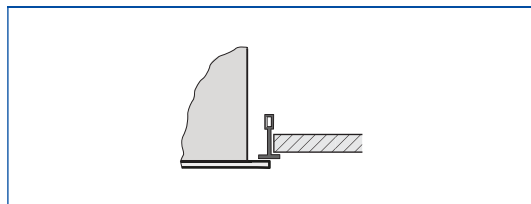

- Fix the plenum box to the ceiling
- The T-bar ceiling is independent of the ceiling diffuser
- Fix the diffuser face below the T-bars after the ceiling has been completed

### Installation in T-bar ceilings, diffuser face rests on T-bars

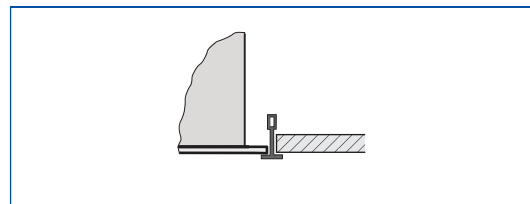

- Fix the plenum box to the ceiling, if necessary
- The diffuser rests on the T-bars

### Diffuser face sealing and fixing

#### Diffuser face – sealing

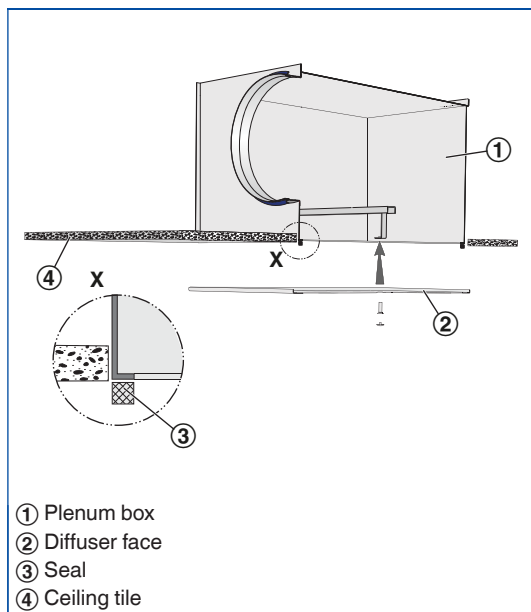

- ① Plenum box
- ② Diffuser face
- ③ Seal
- ④ Ceiling tile

- The self-adhesive sealing tape (supplied) has to be applied to the return edges of the plenum box by others

#### Diffuser face – central screw fixing

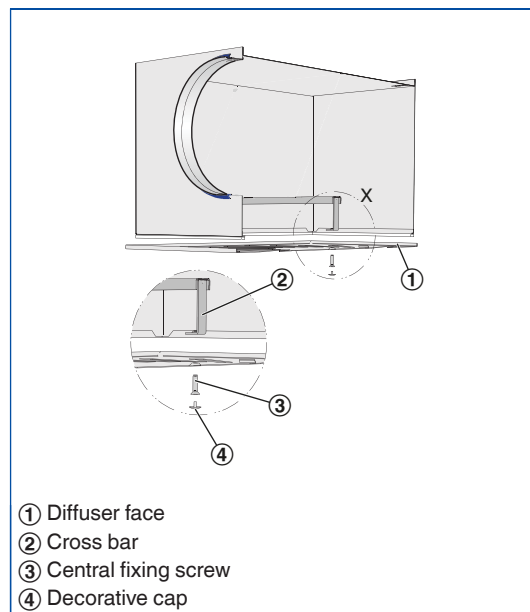

- ① Diffuser face
- ② Cross bar
- ③ Central fixing screw
- ④ Decorative cap

- Using the central fixing screw, fix the diffuser face to the cross bar of the plenum box
- Attach the decorative cap

### Commissioning

1

#### Volume flow rate balancing

When several diffusers are connected to just one volume flow controller, it may be necessary to balance the volume flow rates.

- AIRNAMIC, XARTO, FLEXTRO:  
The diffuser face can be removed to access the damper blade; the damper blade can then be set in 15° intervals between 0 and 90°
- Ceiling diffusers with universal plenum box and damper blade (variant -M):  
The diffuser face can be removed to access the damper blade; the damper blade can then be set to any position between 0 and 90°
- Ceiling diffusers with universal plenum box, damper blade and pressure tap (variant -MN):  
The diffuser face need not be removed since the damper blade can be set with two cords (white and green).

#### AK-Uni-...-MN Volume flow rate balancing

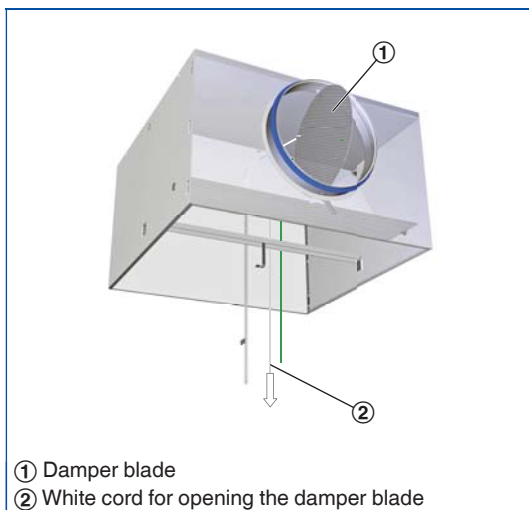

Open, 0°

#### AK-Uni-...-MN Volume flow rate balancing

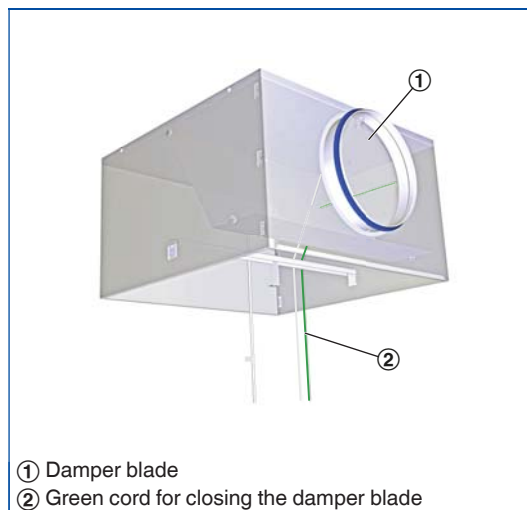

Closed, 90°

#### AIRNAMIC, XARTO, FLEXTRO Volume flow rate balancing

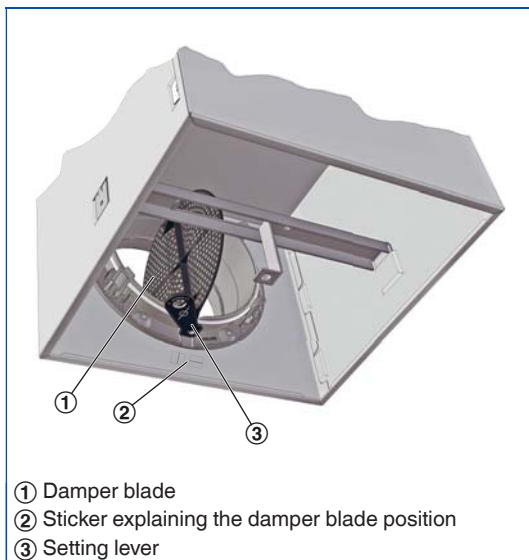

Open, 0°

#### AIRNAMIC, XARTO, FLEXTRO Volume flow rate balancing

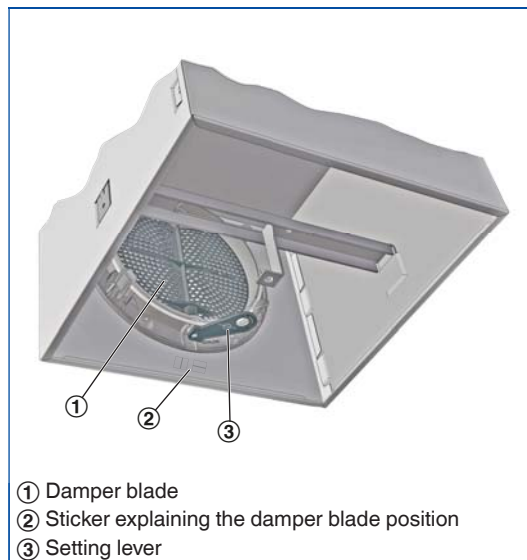

Closed, 90°

### Volume flow rate measurement

Ceiling diffusers with universal plenum box, damper blade and pressure tap (variant -MN) allow for volume flow rate balancing even with the diffuser face in place.

- Connect the measuring tube to the digital manometer
- Read the effective pressure
- Read the volume flow rate off the characteristic or calculate it
- If necessary, adjust the damper blade position with the cords

A characteristic is included with each AK-Uni plenum box.

### AK-Uni...-MN volume flow rate measurement

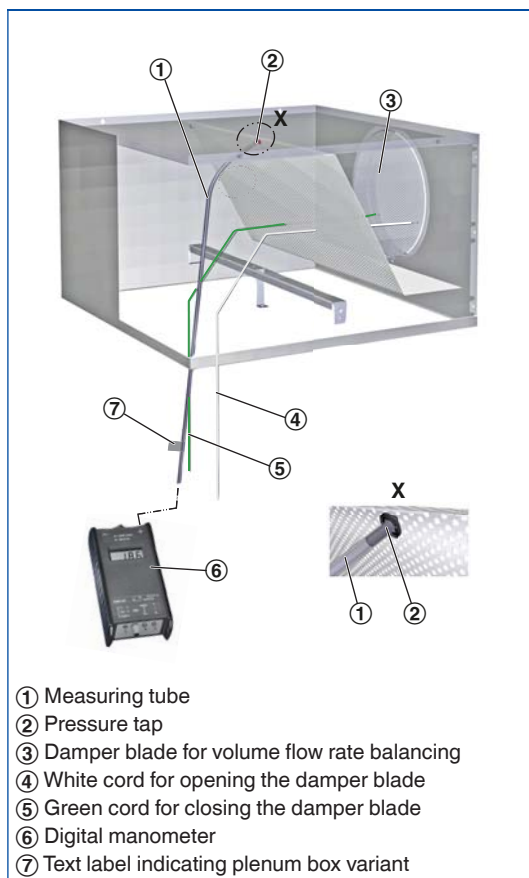

For K values for the AK-Uni plenum boxes refer to Chapter K1 – 1.5.

### Volume flow rate calculation for air density 1.2 kg/m<sup>3</sup>

$$\dot{V} = C \times \sqrt{\Delta p_w}$$

### Volume flow rate calculation for other air densities

$$\dot{V} = C \times \sqrt{\Delta p_w} \times \sqrt{\frac{1.2}{\rho}}$$