

AIRFOIL

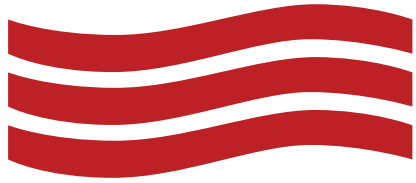

GRILLES
DUCT
FITTINGS

making it happen sooner...



Quality
Endorsed
Company
ISO 9001
 SAI GLOBAL



**POLY BOARD UNI BOOT
PB-UB**



POLY BOARD UNI BOOT PB-UB

PRODUCT DESCRIPTION AND APPLICATION

Airfoil's Australian Made 20mm Polyurethane Foam Pre-Insulated Poly Board Uni Boot (PB-UB) is a light weight Fire Rated alternative to our Sheet Metal range. The Poly Board aluminium sheeted exterior is coated with a 2g/m² resistant epoxy varnish further enhancing its insulation qualities guaranteeing durability and reliability.

They have a spigot placement **opposite to the open end of the boot**. This particular configuration is useful in areas of restricted ceiling space. The Poly Board Uni Boot is predominantly used in side blow applications where it may be necessary to achieve maximum throw across the conditioned space.

Designed to seamlessly integrate with Airfoils' Supply Air Grille range this quality Poly Board Uni Boot ensures compatibility and efficiency. Suitable for commercial settings where thermal and acoustic requirements are paramount, it stands as a testament to Airfoil's commitment to excellence in Poly Board solutions.

POLY BOARD UNI BOOT PB-UB

PRODUCT SPECIFICATIONS AND INFORMATION

- **Product ordering code – PB-UB**
- Australian Made and Designed
- Custom made to any size (order by internal opening size)
- Standard Uni Boot depth 150mm (not including spigot)
- Manufactured from 20mm Polyurethane Foam (Pre-Insulated)
- Aluminium Outside / Black-Faced internal
- R-Value
- Light weight
- Coated with 2g/m² resistant epoxy varnish
- Density = 66kg/m³
- Available with optional 20mm C-Extrusions cover attachment trim
- Easy installation
- Spigot placement is **opposite to the open end** of the boot (top entry)
- Custom box heights manufactured to suit grille requirements
- Mounted behind grille
- Acoustic qualities
- Thermal qualities
- Customised oval spigots available to suit varying box height restrictions
- Spigot sizes available are 100mm, 150mm, 200mm, 250mm, 300mm, 350mm, 400mm, 450mm, 500mm, 550mm and 600mm diameters
- Used for supply and return air in heating and cooling
- **Tested information available (AWTA)**



POLY BOARD UNI BOOT PB-UB

CROSS SECTIONAL DIAGRAM

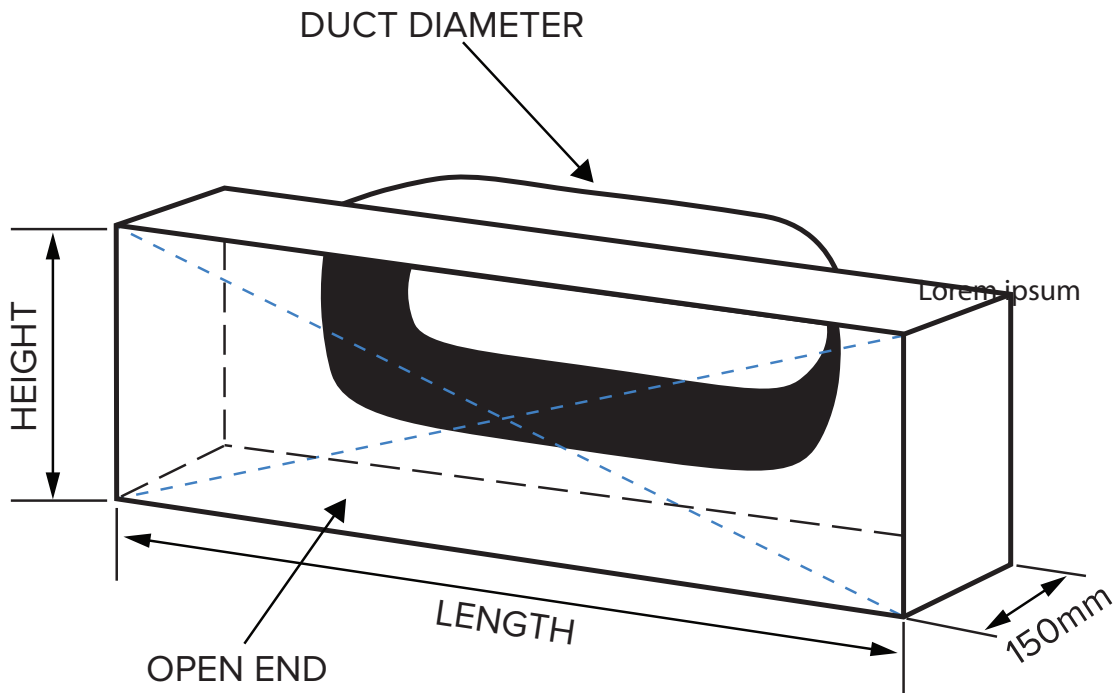

SPIGOT PLACEMENTS **OPPOSITE THE OPEN END** POLY BOARD UNI BOOT (PB-UB)



DISCLAIMER:

All product designs, data sheets and specifications presented herein are the intellectual property of Airfoil Manufacturing Pty Ltd. These designs and specifications, including but not limited to diagrams, drawings, and performance data, are protected under Australian intellectual property laws. No part of these designs and specifications may be copied, reproduced, distributed, or transmitted in any form or by any means without the prior written permission of Airfoil Manufacturing Pty Ltd. Unauthorised use or reproduction of these materials may result in legal action under Australian copyright and intellectual property laws.

POLY BOARD UNI BOOT PB-UB

PU FOAM PRE-INSULATED PANEL (20MM THICK)

Polyurethane Foam Pre-insulated Panels consists of 20 mm thickness with aluminium foil, aluminium sheet or Galvanised Iron on both or either sides. The aluminium foil is coated with a 2g/m² layer of corrosion-resistant epoxy varnish paint which also acts to reduce fungus and mold growth.

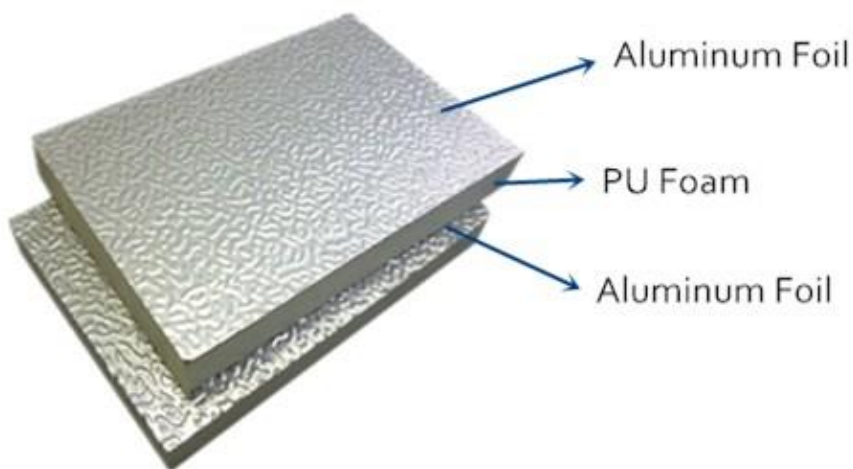

The aluminum foil can be produced in silver, white or black colour, with a smooth or embossed finish. The surface of the panel also can be aluminum sheet, GI or printed color steel, as per the images below:

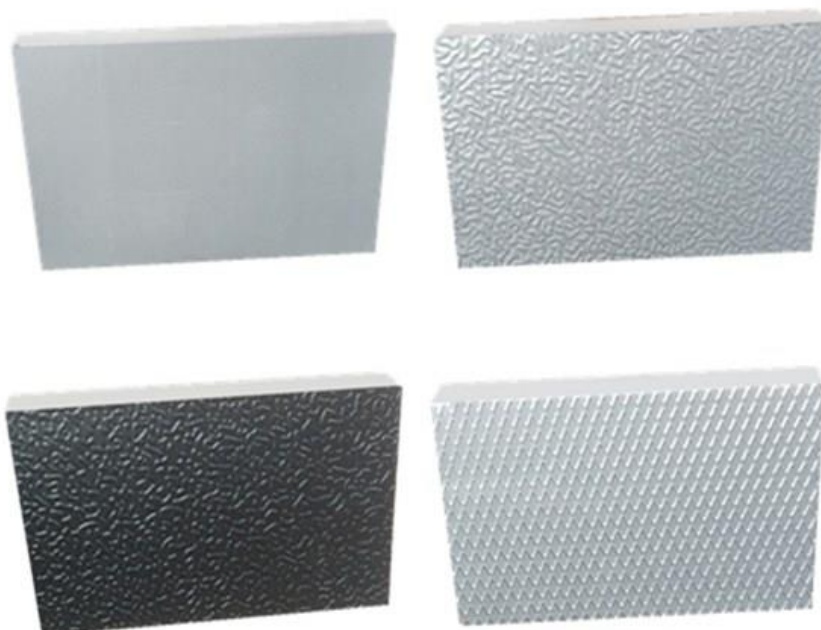

POLY BOARD UNI BOOT PB-UB

TECHNICAL DATA PU FOAM PRE-INSULATED PANEL (20MM THICK)

PROPERTY	UNIT	SPECIFICATION
Standard Size	mm	3950*1200*20
Foam Density	kg/m ³	50-55
Aluminium Foil Thickness	micron	80
Aluminium Sheet Thickness	micron	200
Thermal Conductivity	W/m.K	0.02
Thermal Resistance	R-Value	R1.0 (AS/NZS 4859 - ASTM C518 -2017)
Fire Rating	3 Zero	AS/NZS 1530.3-1999
Compressive Strength	Mpa	0.25
Bending Strength	Mpa	2
Water Absorption	%	0.01
Dimension Change	%	0.3
Maximum Wind Velocity	m/s	13-20
Maximum Running Temperature	°C	80

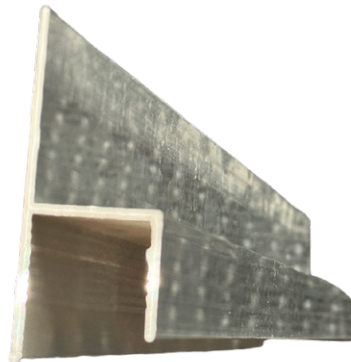

OPTIONAL C-EXTRUSION COVER ATTACHMENT TRIM