

# AIRFOIL



GRILLES  
DUCT  
FITTINGS

*making it happen sooner...*



Quality  
Endorsed  
Company  
ISO 9001  
 SAI GLOBAL

**METAL EXHAUST VALVE  
MEV200**





## METAL EXHAUST VALVE MEV200

### PRODUCT DESCRIPTION AND APPLICATION

The Airfoil Metal Exhaust Valve (MEV200) is expertly engineered from high-grade, lightweight spun steel, combining exceptional durability with a modern aesthetic. Purpose-built for flush ceiling-mounted installations, its sleek design seamlessly complements any interior, adding a refined touch of sophistication to both commercial and residential spaces. The MEV200 is versatile, making it ideal for both heating and cooling exhaust applications.

Designed to handle various airflow rates, the MEV200 maintains low pressure drops and minimal noise, ensuring efficient and quiet operation. The valve comes equipped with a robust mounting ring, providing added strength and rigidity during installation.

The centre cone, which facilitates smooth and efficient exhaust airflow, is fully adjustable, allowing for precise control over air distribution to meet specific ventilation requirements. For added flexibility, our Flexible Duct can be directly connected to the mounting ring at the valve's rear, ensuring seamless integration.

Available in two sizes and finished in our standard white, the MEV200 can also be powder-coated in any custom colour upon request, offering design flexibility for a range of projects. This versatile exhaust valve is suitable for various commercial and domestic exhaust air applications.

## METAL EXHAUST VALVE MEV200

### PRODUCT SPECIFICATIONS AND INFORMATION

- **Product ordering code – MEV200**
- Constructed from high-grade light weight spun steel
- Neck size 197mm to suit 200mm diameter flexible duct attachment
- Cut out size 200mm
- Face Size 248mm
- Frame depth 63mm
- Used for exhaust air applications
- Capable of handling various airflow rates
- Adjustable centre cone
- Comes complete with mounting ring
- Ideal for flush ceiling mounted applications
- Available in our standard white range
- Special powder-coated colours available on request
- Product suitable for various commercial and domestic exhaust air applications
- Airfoil tested information available



## METAL EXHAUST VALVE MEV200

### CROSS SECTIONAL DIAGRAM

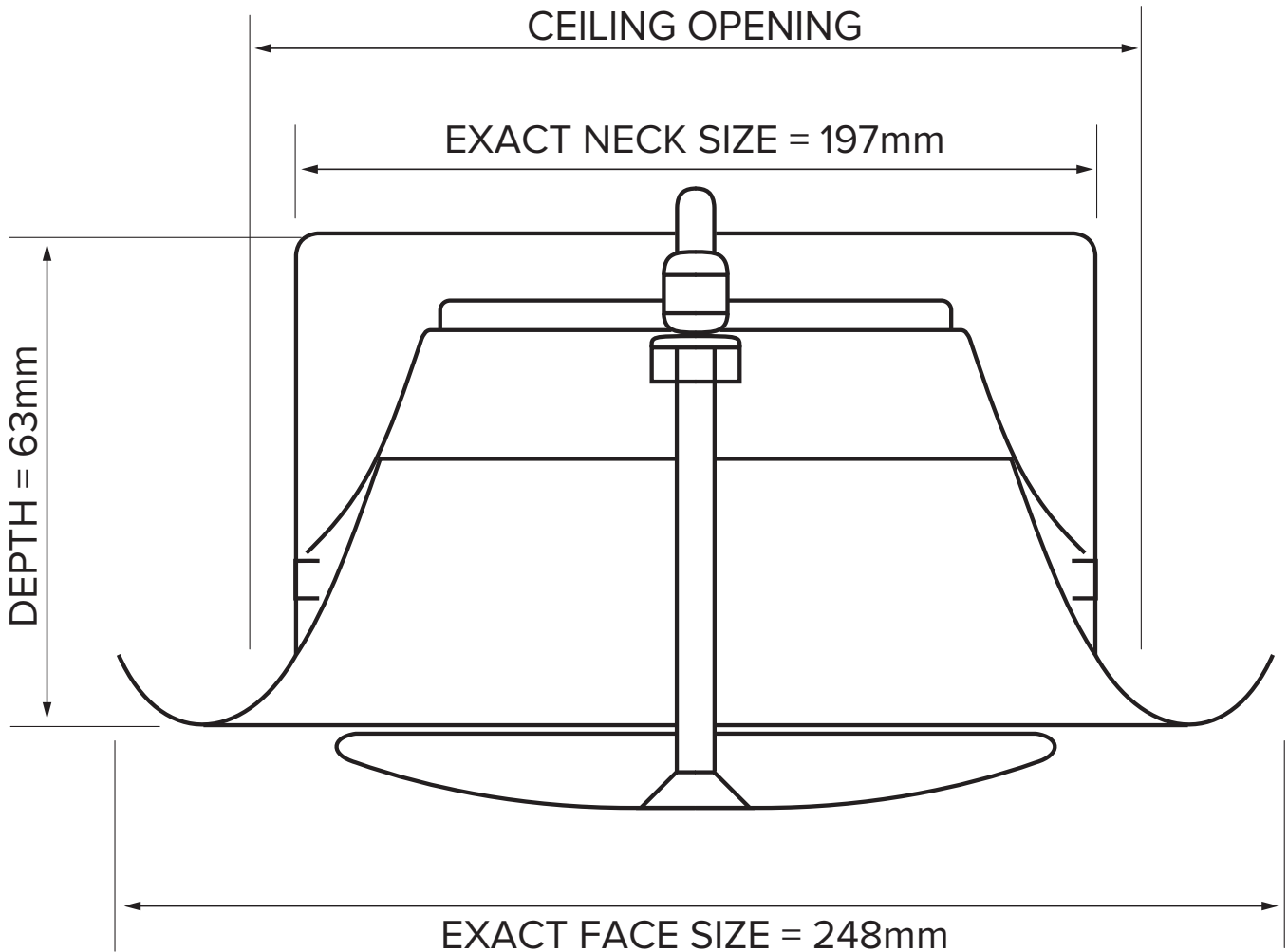

#### DISCLAIMER:

All product designs, data sheets and specifications presented herein are the intellectual property of Airfoil Manufacturing Pty Ltd. These designs and specifications, including but not limited to diagrams, drawings, and performance data, are protected under Australian intellectual property laws. No part of these designs and specifications may be copied, reproduced, distributed, or transmitted in any form or by any means without the prior written permission of Airfoil Manufacturing Pty Ltd. Unauthorised use or reproduction of these materials may result in legal action under Australian copyright and intellectual property laws.

## METAL EXHAUST VALVE MEV200

### PERFORMANCE DATA

Valve Opening	Performance Data	MEV200					
25% Open	Air Flow (l/s)	40	50	60	70	80	90
	Noise Criteria (NC)	15	21	27	31	39	43
	Pressure Drop (Pa)	24	39	56	77	101	128

Valve Opening	Performance Data	MEV200					
100% Open	Air Flow (l/s)	40	50	60	70	80	90
	Noise Criteria (NC)	<15	15	17	20	22	26
	Pressure Drop (Pa)	3	5	7	10	13	16